

1/48 ICM Ju 88 A-5 correction set & A-1 conversion

■ Remove / fill
■ Add
Surgery

Remove cockpit floor

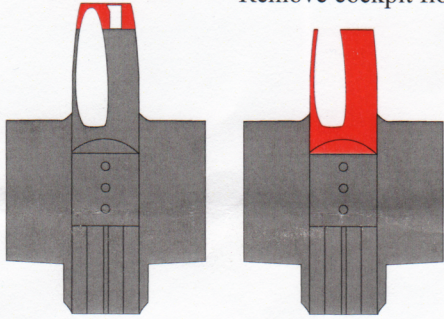

Remove front of engine and rear hot air ducts, separate engine from gear bay and reduce A-4 style bulge of front exhaust stack fairing

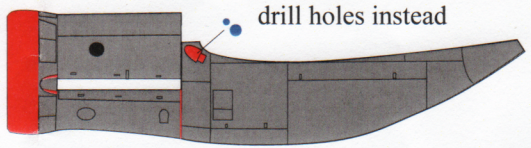

If making A-1, swap exhaust banks over so 6 stack is on left of engine facing forward. Modify right side bank by changing long section into one more stack at the front to make 5x stacks - long section - 1x stack

Remove forward section and rejoin to resin part

If making A-1, remove wing wips from outer aileron hinge; add resin A-1 wingtip and cut kit aileron to size

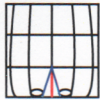

Delete canopy frame and add correct slanting sections

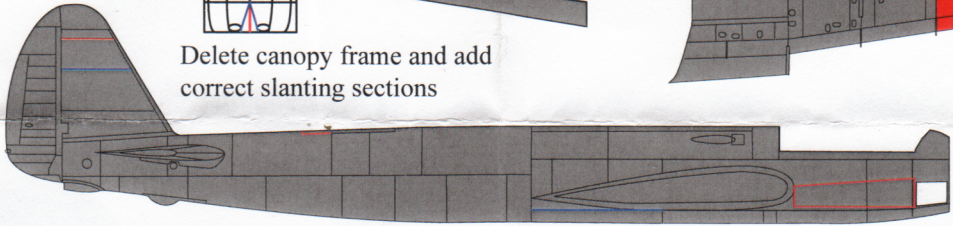
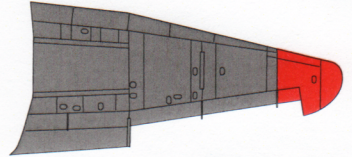

Delete upper panel line on vertical stabilizer, delete control cable panel from right side cockpit. If making A-1 reduce rear of dinghy hatch by 10mm and also delete hand holds along top of fuel cell on the left side. Add missing outer bomb bay hinge line to both sides.

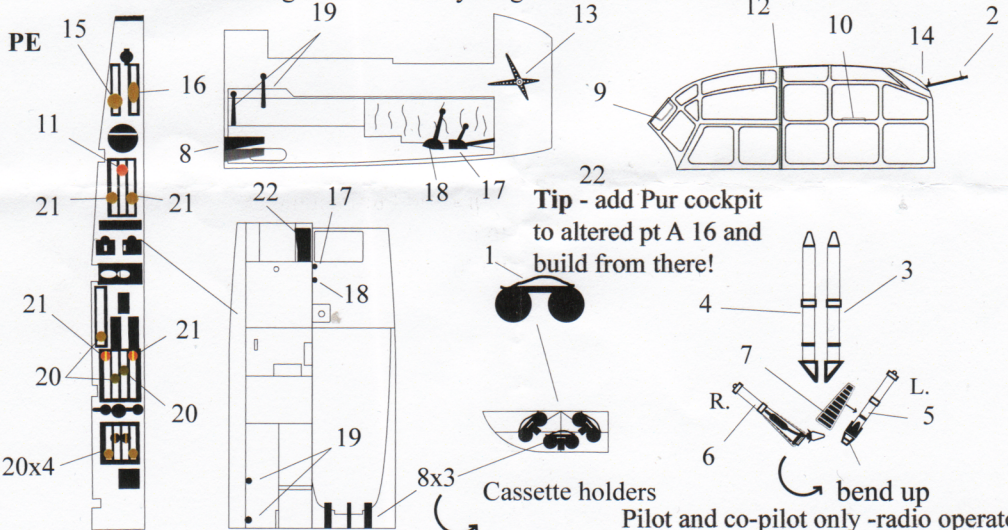

Tip - add Pur cockpit to altered pt A 16 and build from there!



Cassette holders

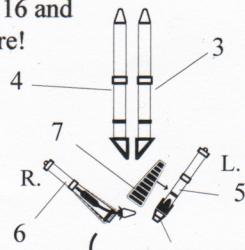

bend up

Pilot and co-pilot only - radio operator and engineer lap belts only